

A compact version of the versatile 333 Timer, the ATC 353 is its exact functional duplicate. Packaged in a 72mm² DIN-Size housing, it occupies 40% less panel space and costs proportionately less. Modern production and assembly techniques have all but eliminated hand wiring, enhancing the reliability and life expectancy of the 353.

CONTROL VERSATILITY: The 353 operates either as a repeat cycle pulse generator or in single-cycle interval or delayed mode. You choose the kind of control action you want by installing jumpers on the terminal block. It also provides a choice of control output. Choose a standard plug-in SPDT relay or optional SPST solid-state switch module plus an independent-24VDC output signal at Terminal 16.

COMPUTER TESTED RELIABILITY: The solid-state 353 is manufactured from a series of computer-tested plug-in circuit boards and assembled virtually without hand wiring. Because it has no moving parts in its logic circuits, its life expectancy is practically unlimited. Even the load relay — the 353's only significant mechanical component — has a life expectancy of 100,000,000 operations (no load), while the optional solid-state switch module has virtually unlimited life expectancy. As a result, the 353 achieves an overall reliability that surpasses even the high level achieved by previous Shawnee timers.

SAVE 40% IN PANEL SPACE AND COST: Packaged in a 72mm² DIN-size housing, the 353 occupies 40% less panel space than previous IC timers. Modern production and assembly techniques have substantially reduced manufacturing costs and resulted in a 45% cost saving.

WIDE RANGE: Each Shawnee II 353 timer covers the overall span of 0.01 SEC to 999.9 MIN in four field-convertible ranges.

EASY TO SET: The Shawnee timer is easily and accurately set even with work gloves on. Push any of its four toggle levers in any sequence until the number you want appears above it. You can decrease as well as increase each number by pushing the levers up or down. You can change the setting at any time, even during a cycle.

NOISE IMMUNITY: The 353 does not have to be shielded: its transformer power supply, full-wave bridges, buffered logic and other design characteristics render it immune to the electrical noise that is sometimes encountered in industrial environments thus eliminating false starts and reset due to voltage spikes.

CYCLE PROGRESS INDICATION: The Shawnee 353 indicating timer provides cycle progress indication on a four-digit display located immediately above the digital setting number wheels.

OUTSTANDING REPEAT ACCURACY: Unsurpassed among industrial timers regardless of cost, the Shawnee 353 has a repeat accuracy of ± 10 milliseconds on any setting within its overall range of 999.9 MIN, even in the face of wide swings in temperature or voltage and regardless of the amount of reset time between cycles.

PLUG-IN AND DUST-TIGHT: All 353 timers feature true plug-in design and are dust-tight from the front of panel.



Shawnee II Digital Programmable Timer

MODEL NUMBER

MODEL NUMBER	353C			30	P	
RANGE						
999.9 SEC	346					
999.9 MIN	347					
99.99 SEC	351					
99.99 MIN	352					
Special	000					
VOLTAGE & FREQUENCY						
120/60			A			
240/60			B			
120/50			C			
240/50			D			
ARRANGEMENT						
With Display (On Delay)				30		
FEATURES						
Basic plug-in unit					P	
Standard unit						X
Special						K

ACCESSORIES:

Surface mounting bracket kit	353-260-27-00
Retrofit kit	305-265-61-70

The 353C Directly Replaces 353B & 353A
Functional Replacement for the 333 Timer

SPECIFICATIONS

RANGES	Four field convertible ranges 0.01 - 99.99 SEC 0.01 - 99.99 MIN 0.1 - 999.9 SEC 0.1 - 999.9 MIN
TIMING MODES	Single cycle (interval or delayed) and repeat cycle pulse generator.
VOLTAGE REQUIREMENTS	
START/RESET SIGNAL	VOLTAGE REQUIREMENTS Positive Polarity Ready at 4.5V min. Reset at 1.0V max. Negative Polarity Ready at 3.0V min. Reset at 1.0V max Max. Continuous Input 40V. Ripple Voltage must not go below minimum required AC Line Voltage Input Impedance 5K ohms.
	RESET TIME Circuit Reset 1 mSEC max. Relay Drop-Out 20 mSEC max.
	START SWITCH REQUIREMENTS (ISOLATED CONTACT) Switch Rating 10mA 30V Min Open Resistance 1 megohm Max. Closed Resistance 20K ohms
	LATCHING MODE OPERATION (INTERVAL ONLY) Min. Duration 50 μSEC Start Signal Max. Duration continuous Start Signal Reset when signal is removed

TEMPERATURE RATING	32° to 140°F (0 to 60°C)
POWER REQUIREMENTS	120V 95 to 132V, 50/60 Hz inrush - 0.4 A running - 0.04 A 240V 190 to 264V, 50/60 Hz inrush - 0.2 A running - 0.02 A ±10%

WIRING

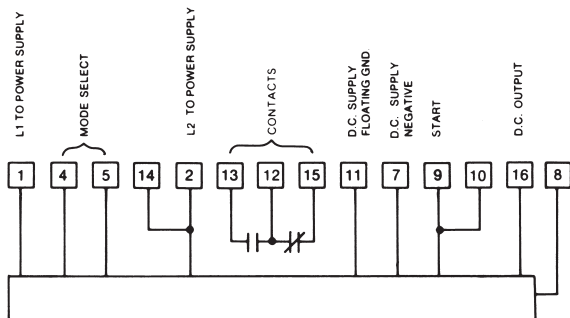

DC POWER	Voltage -24V ± 10%
SUPPLY OUTPUT (TERMINAL 7)	Current 40 mA max.
DC OUTPUT (TERMINAL 16)	Voltage ON - -24V ± 10% OFF - -1V or less Current with relay-5 mA max. without relay-40 mA max Impedance on - 10 ohms max. off - 10K ohms.
PULSE GENERATOR OPERATION	PULSE ON TIME (with relay): 80 mSEC ± 20 mSEC (may be shortened or lengthened by installing a resistor or capacitor, respectively, across Terminals 4 and 11; see Operation Section for details.)
LOAD RELAY	LIFE 100,000,000 operations (no load.) CONTACT RATING: 5A @ 120 VAC Resistive, 5A, 30 VDC Resistive
REPEAT ACCURACY	±0.01 SEC on all ranges.
MINIMUM SETTING	99.99 SEC or MIN ranges: 0.01 SEC or MIN, respectively. 999.9 SEC or MIN ranges: 0.1 SEC or MIN, respectively.
MOUNTING ACCESSORIES	Standard Hardware is provided to mount timer so that it is dust-tight from front of panel. Optional Surface mounting without and with front facing terminals. (See Accessory section of catalog)
WEIGHT	NET: 1 lb., 7 oz. Shipping: 2 lbs.

DIMENSIONS (INCHES)

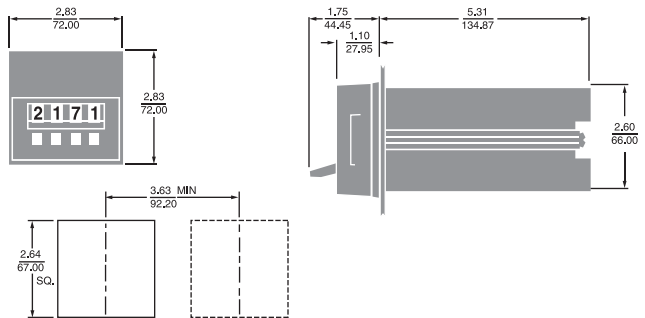

PANEL CUTOUT SHOWING DISTANCE BETWEEN ADJACENT CUTOUTS.

TERMINAL WIRING

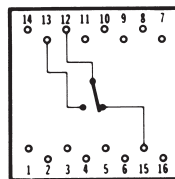

OPERATION

The Shawnee 353 operates on a digital logic circuit with three main elements: a clock which uses utility line frequency of 50 or 60 Hz as its time base; a read-only-memory (ROM) whose output is set by the timer's digital setting number wheels; and a comparator that continuously examines the outputs of the clock and ROM.

When power is applied (start signal on), the clock begins to count each cycle of the utility line frequency. Translating this count into hundredths of a second, the clock accumulates it and feeds it continuously to the comparator. When clock output exactly equals the output of the ROM, the 353 times out.

At that instant, the clock turns itself off automatically.

At the same instant, the 353 generates one type of control action or another, depending on how it is wired.

When the 353 is wired for interval operation, the timer's output device (either the standard SPDT relay or the optional SPST switch module) is energized from the start to the end of the time cycle; so is the -24 VDC output at terminal 16.

When the 353 is wired for delayed control, the output device is energized at the end of the cycle and remains on until the timer is reset; so is the -24 VDC output.

When the 353 is wired as a repeat cycle pulse generator, the output device and the DC signal are both off until the end of the cycle, at which time they are both on for about 80 mSEC. The length of the pulse is included in the time cycle: the cycle runs from the start of one pulse to the start of the next. The 353 automatically starts a new cycle immediately after reset.

The duration of the standard output pulse generated by the 353 is 80 mSEC (± 20 mSEC), but it can be easily lengthened or shortened by using a capacitor or resistor across terminals 4 and 11. To shorten the output pulse, the size of the resistor (fixed or variable) is calculated as follows:

Where: $t = \text{time in milliseconds } (\pm 25\%)$ $\frac{2.2t - 2.64}{80 - t} = R$

R = resistance in megohms
(must be at least 0.2 megohm.)

To lengthen the output pulse, the size of the capacitor is calculated as follows:

Where: $T = \text{time in seconds } (\pm 25\%)$ $\frac{T - 0.08}{1.6} = C$

C = capacitance in microfarads.

NOTE Observe Polarity: (+) Terminal of the capacitor goes to 11, (-) Terminal to 4. To start from AC voltage, jumper terminals 8-9 and 4-11 and start with AC power at terminals 1 and 2.

TYPICAL INSTALLATION

DELAYED MODE — Sustained* start

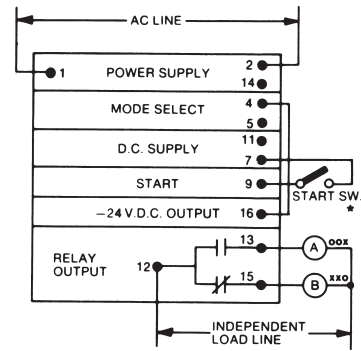

INTERVAL MODE — Sustained* or momentary** start

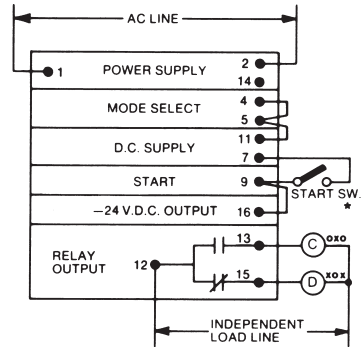

INTERVAL MODE — Sustained* start

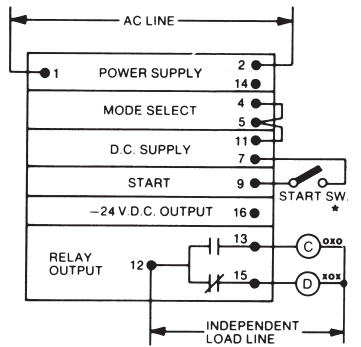

REPEAT CYCLE PULSE GENERATOR — Uninterrupted start signal

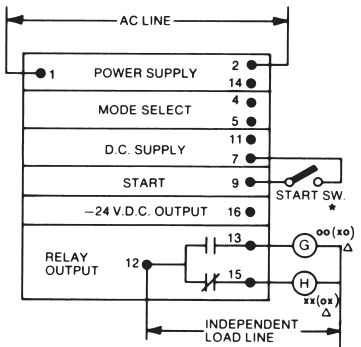

*Start switch must be closed — or DC start signal must be on — for entire cycle. Timer resets when start switch opens or DC start signal turns off. To start from DC voltage, apply external ground on 11 and start signal on 9.

**Start switch may be closed — or DC start signal may be on — for less than the entire cycle. Timer resets at end of cycle.