

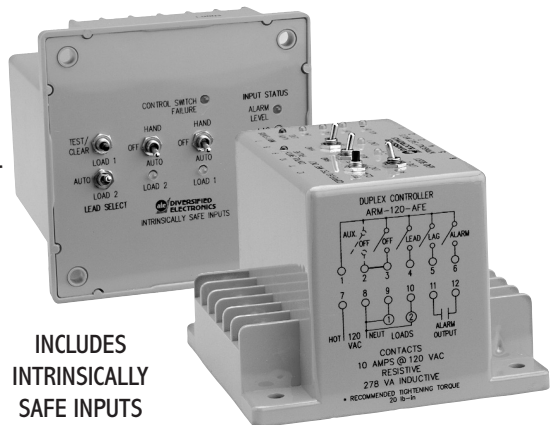

Process Control Equipment for Hazardous Locations
7M26
UL913



INCLUDES INTRINSICALLY SAFE INPUTS

Integrated Duplex Controller SOSO Operation (Sequence-on, Simultaneous-off)

The **ARM Series** Alternating Relay is a **microprocessor-based controller** designed for use in dual load installations to assure equal run time on each load. LED indicators show the status of the unit's five intrinsically safe control switch inputs, one alarm, and two load outputs. H-O-A switches, a lead select switch, and a test/clear button are provided for manual control. The ARM Series reduces the number of components required for this application by combining many functions into one unit.

TWO PUMP SEQUENCING: Evenly distributes run time by automatically alternating lead and lag load designations when the off control switch input opens.

UL913 INTRINSICALLY SAFE: Control switch inputs are low voltage/low current and are electronically isolated from the control voltage and load alarm contacts.

H-O-A Switches: Hand-Off-Automatic switches allow for manual operation.

LEAD SELECT SWITCH: Disables the automatic sequencing function and allows loads to be locked into the 2-1 or 1-2 sequence.

CONTROL SWITCH FAULT DETECTION: Unit detects open and shorted control switch failures.

TEST/CLEAR SWITCH: Verifies function and resets the control switch fault detection algorithm.

ALARM OUTPUT: Alarm contacts close when a control switch fails or the system's capacity is exceeded.

INRUSH CURRENT DELAY: Reduces line sags by preventing both loads from energizing simultaneously.

VERSATILE MOUNTING: Two (2) mounting configurations are available. The standard surface mount has top access to controls and indicators and is intended for back panel mounting. The panel mount option is intended for front panel or door cutout access to controls and indicators.

SPECIAL CONTROLS: **ARM-2003** and **ARM-2010**—Standard operation without the H-O-A switches **ARM-2011**—Standard operation without the Control Switch Failure feature.

SPECIFICATIONS

CONTROL VOLTAGE	24 or 120 VAC ±10%, 50/60 Hz		
CONTROL SWITCH	Open Circuit Voltage	5 VDC	
	Short Circuit Voltage	0.1 mA	
POWER REQUIRED	4 VA Maximum		
DUTY CYCLE	Continuous		
RESPONSE	Power Up	3 SEC. ±5%	
	Inrush Current	5 SEC. ±5%	
CONTACT RATING	(3) SPST-N.O. 10 Amp Resistive, 1/4 hp, 278 VA Inductive @ 120 VAC		
LED INDICATORS	Designation	Color	State Condition
	Level/Alarm	Red	ON cs5 Closed
	Lag	Green	ON cs4 Closed
	Lead	Green	ON cs3 Closed
	Off	Green	ON cs2 Closed
	Aux. Off	Green	ON cs1 Aux./cs2 Closed
	Load 1	Green	ON Load ON
	Load 2	Green	ON Load ON
	Ctrl. Switch	Red	ON Failure Open/Closed
LIFE EXPECTANCY	Mechanical	20 Million Operations	
	Electrical	75,000 @ Rated Load	
TEMPERATURE RATING	Operate	-4° to 131°F (-20° to +55°C)	
	Storage	-40° to 185°F (-40° to +85°C)	
TERMINATIONS	(12) #8-32 Screw Terminals		
WEIGHT	16 oz.		

ORDERING INFORMATION

MODEL NUMBER	CONTROL VOLTAGE	MOUNTING	COMMENTS
ARM-XXX-AFE*	24 or 120 VAC	Surface	Standard
ARM-XXX-AFEP*	24 or 120 VAC	Panel	Standard
ARM-2003	120 VAC	Surface	Special: w/o H-O-A switches
ARM-2010	120 VAC	Panel	Special: w/o H-O-A switches
ARM-2011	120 VAC	Surface	Special: w/o Control switch failure feature

*Replace XXX with desire control voltage (24, 120)

The ARM Series is UL Listed under UL File Number E151578.

DIMENSIONS (INCHES)

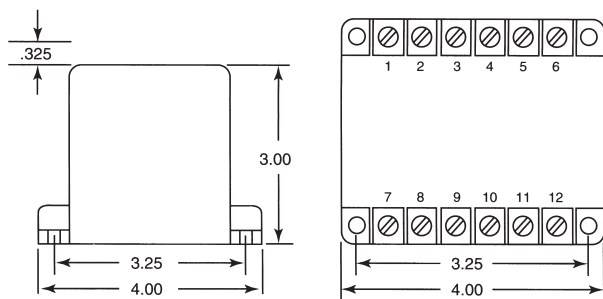

*Panel Mount Cutout

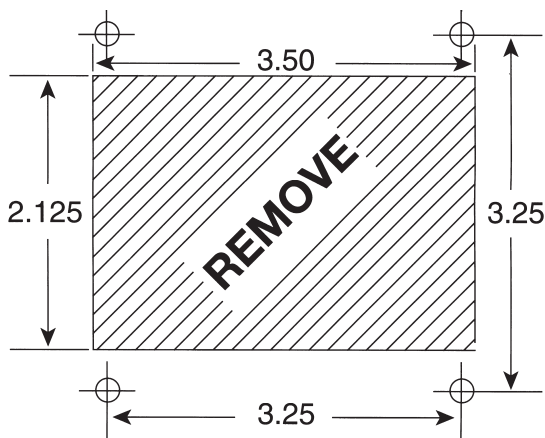

*Greenlee punch #60071 or equivalent

OPERATION

FOUR CONTROL SWITCHING: Do not remove factory-installed jumper between terminals 2 and 3. The control switches connected to terminals 3 through 6 are labeled OFF (CS2), LEAD (CS3), LAG (CS4) and ALARM (CS5). Under normal operation the lead load energizes when the off and lead control switches close in order. The lag load energizes when the lag closes and the alarm load energizes when the alarm switch closes. When all four switches reopen in the proper order all outputs are de-energized and the lead/lag output designations reverse.

FIVE CONTROL SWITCHING: Remove factory installed jumper between terminals 2 and 3. After the jumper has been removed, the additional control switch is connected to terminal 2. The extra switch functions as an AUXILIARY OFF (CS1) switch. It is used to prevent loads from running continuously if the primary OFF (CS2) switch fails to open properly.

FAULT DETECTION ALGORITHM: If any of the control switches open or close out of order, the alarm output energizes and a fault detection algorithm is used to identify the faulty switch. The faulty switch is then ignored and the OFF, LEAD, and LAG control switch designations are altered to maintain safe operation.

WIRING

CONTROL DRAWING 190

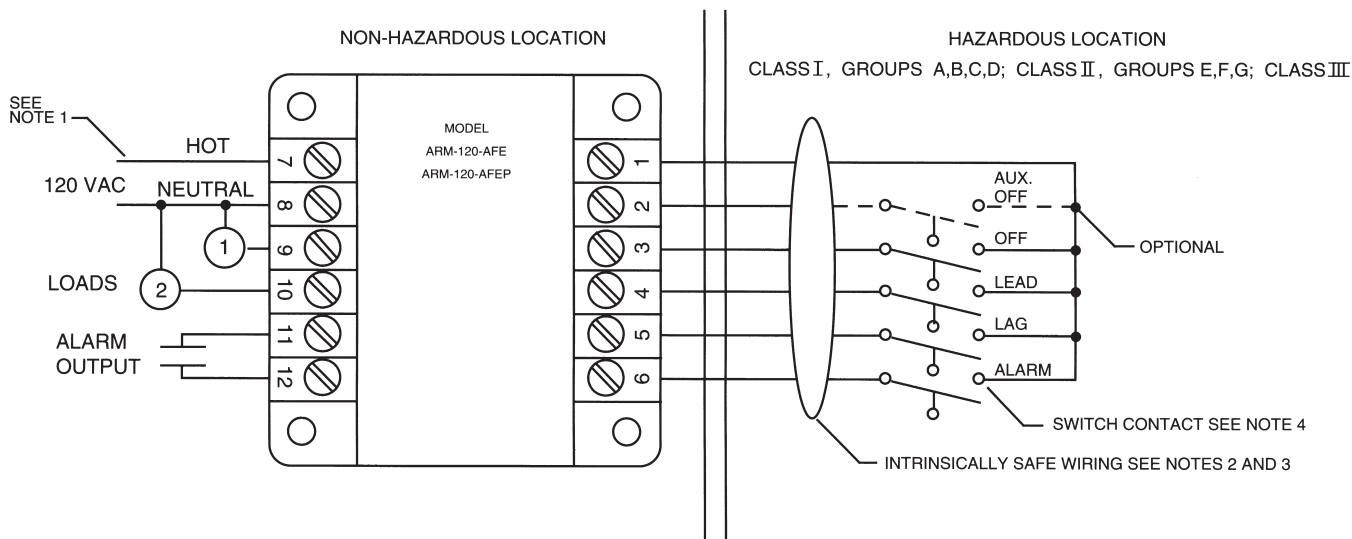

1. To maintain intrinsic safety, connect the Controller's Earth Ground Terminal 8 to the earth ground of the AC Power Supply feeder. The resistance between the Controller's Earth Ground Terminal and Earth Ground shall be less than 1 ohm.
2. Maximum distance between Controller and switch contact is 1000 feet.
3. All intrinsically safe wiring shall be separated from non-intrinsically safe wiring. Refer to article 504 of the National Electrical Code ANSI/NFPA 70 on procedures for intrinsically safe wiring.
4. Switch contact shall be any non-energy storing or generating mechanical switch type device containing no capacitance or inductance.
5. Connections to terminals 5, 6, 9, 10, 11, and 12 are optional. If the Aux. Off switch is omitted, terminals 2 & 3 must be jumpered.