

R627 High Flow Gas Regulator with Internal Relief

The R627 Relieving Regulator has an internal relief valve that provides protection against over pressurization. As output pressure builds up above the start-to-discharge point the relief seat disengages from the diaphragm and the excess pressure is relieved through the bonnet vent port. As a result, the output pressure reduces and returns to the initial setpoint. The relief seat then reseats against the diaphragm. The action of the R627 internal relief valve in many cases eliminates the need for an external relief valve. The R627 is available in spring ranges from 5-20 PSIG up to 70-150 PSIG.

The R627 contains a relief indicator that is attached to the R627 vent assembly. The indicator pops off the vent when the relief valve opens and serves as a visual indicator that the relief valve has operated.



Applications

- Farm Tap
- Gas Gathering
- City Gates
- District Gates

Materials of Construction

Body, Bonnet, Diaphragm Case	
Options	Steel Body, Bonnet & Diaphragm Case
	Cast Ductile Iron Body / Aluminum Bonnet & Diaphragm Case
	Steel Body / Aluminum Bonnet & Diaphragm Case (NACE only)
	Steel Casing / LCC Body
	Aluminum Casing / LCC Body
CF8M Stainless Steel Body, Bonnet & Diaphragm Case	
Diaphragm	
Option	Nitrile (low pressure)
Seat	
Options	Nitrile
	Nylon
	Fluorocarbon
Orifice	
Options	Aluminum
	Stainless Steel (NACE only)

Specifications

Maximum Inlet Body Pressure		
Nylon Seat	2000 PSIG	Steel
	1000 PSIG	Ductile Iron
	1485 PSIG	Flanged Steel
Nitrile Seat	1000 PSIG	All Units
Fluorocarbon Seat	300 PSIG	All Units
Outlet		
	5-150 PSIG	
Body Sizes		
	3/4 NPT	
	1 NPT	
	2 NPT	
Orifice Sizes		
	3/32"	
	1/8"	
	3/16"	
	1/4"	
	3/8"	
	1/2"	
Output		
	Outlet Range	Flow Range*
	5-20 PSIG	300-43,000
	15-40 PSIG	1,000-71,000
	35-80 PSIG	1,200-142,000
	10-95 PSIG	1,000-150,000
	70-150 PSIG	2,500-172,000
* (SCFH of 0.6 S.G. Natural Gas)		
Temperature Range		
	-20° to 180° F	(-29° to 82° C)
Weight Approximate		
1"	5.3 lbs	2.39 kg
2"	8.8 lbs	3.96 kg

Maximum Bonnet and Diaphragm Casing Pressure	Spring & Diaphragm Casing Style	R627		R627M	
		PSIG	BAR	PSIG	BAR
Maximum pressure to spring and diaphragm casing to prevent leak to atmosphere (internal parts damage may occur).	Die Cast Aluminum	250	17.2	250	250
	Steel / SS	250	17.2	250	17.2
Maximum pressure to spring and diaphragm casings to prevent burst of casings during abnormal operation (leak to atmosphere and internal parts may occur).	Die Cast Aluminum	375	25.9	375	375
	Steel / SS	1200	82.7	1200	82.7
Maximum diaphragm casing overpressure to prevent damage to internal parts.	All	120	8.3	120	8.3

R627 Regulator Rebuild Kits

	Kit Includes	Part Number
R627 Nitrile	Nitrile diaphragms (2), Nitrile valve disk, O-rings, back-up rings, and retaining pin	971-R62-700
R627 Nylon	Nitrile diaphragms (2), Nylon valve disk, O-rings, back-up rings, and retaining pin.	971-R62-701

	Kit Includes	Part Number
R627 Nitrile NACE	Nitrile diaphragms (2), SS Nitrile valve disk, O-rings, back-up rings, and retaining pin	971-R62-7N0
R627 Nylon NACE	Nitrile diaphragms (2), SS Nylon valve disk, O-rings, back-up rings, and retaining pin	971-R62-7N1

R627 Part Matrix

R627								1	
	▲	▲	▲	▲	▲	▲	▲	▲	Port Size
	06								3/4"
	08								1"
	16								2"
									Spring Range
									PSIG BAR
	020								5 - 20 0.34 - 1.4
	040								15 - 40 1 - 2.8
	080								35 - 80 2.4 - 5.5
	095								10 - 95 0.7 - 6.6
	150								70 - 150 4.8 - 10.3
									NOTE: Nitrile or FKM is required for 5-20, 15-40 and 10-95 PSIG. Nylon is recommended only up to 1/8" orifice for these pressure ranges.
									Special Adders
	0								None
	2								Monitor
	A								150 #RF*
	B								300 #RF*
	C								600 #RF*
	D								Socket Weld*
	E								900 #RTJ*
	W								150 #RF & Monitor*
	X								300 #RF & Monitor*
	Y								600 #RF & Monitor*
	Z								Socket Weld & Monitor*
									*Steel, LCC Steel or Stainless Steel Bodies Only
									Versions
	0								Standard
	N								NACE
	F								NACE & Fluorocarbon
	T								Stainless Trim
									Orifice
	0								3/32"
	2								1/8"
	3								3/16"
	4								1/4"
	6								3/8"
	8								1/2"
									Seat Material
	0								Nitrile
	1								Nylon
	2								Fluorocarbon
									NOTE: Nitrile or FKM is required for 5-20, 15-40 and 10-95 PSIG. Nylon is recommended only up to 1/8" orifice for these pressure ranges.
									1
									Case / Body
	0								Aluminum / Iron
	1								Steel / Steel
	2								Aluminum / Steel
	6								Aluminum / LCC Steel
	7								Steel / LCC Steel
	8								Steel / Iron
	9								Stainless / Stainless

R627 Relief Performance - 1/4" Orifice

R627 RELIEF PERFORMANCE - P/N R62708020004010 1/4" ORIFICE

5-20 PSIG, Preset @ Po=10 PSIG, Seat Disk Removed, Vent Screen Removed

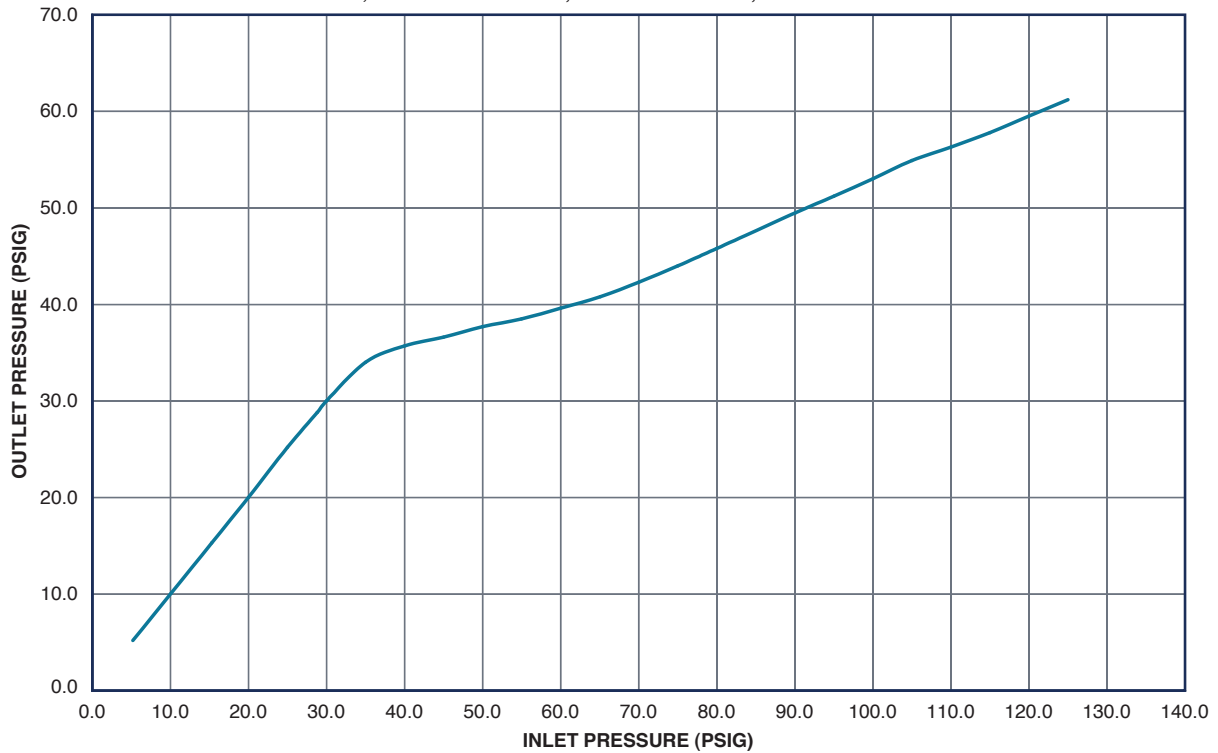

R627 Internal Relief Performance¹

Outlet Pressure Spring Range	Outlet Pressure Setting		Maximum Allowable Downstream Pressure		Maximum Inlet Pressure to Keep Maximum Allowable Downstream Pressure from Being Exceeded ²					
					R627					
					Port Diameter, inches					
PSIG	BAR	PSIG	BAR	3/32	1/8	3/16	1/4	3/8	1/2	
5 to 20 PSIG ³ (.03 to 1.4 BAR)	10	0.7	60	4.1	1250	740	320	190	95	75
			100	6.9	2000	1500	620	390	180	130
			125	8.6	2000	1900	830	480	220	160
			175	12.1	2000	2000	1100	670	320	220
			200	13.8	2000	2000	1300	770	360	260
			250	17.2	2000	2000	1600	960	450	320
	15	1.0	60	4.1	1000	620	260	170	90	70
			100	6.9	2000	1400	610	370	170	130
			125	8.6	2000	1900	810	480	220	160
			175	12.1	2000	2000	1100	670	320	220
			200	13.8	2000	2000	1300	770	360	260
			250	17.2	2000	2000	1600	960	450	320
	20	1.4	60	4.1	850	490	210	130	80	65
			100	6.9	2000	1300	600	360	170	120
			125	8.6	2000	1800	800	480	220	160
			175	12.1	2000	2000	1100	670	320	220
200			13.8	2000	2000	1300	770	360	260	
250			17.2	2000	2000	1600	960	450	320	

Outlet Pressure Spring Range	Outlet Pressure Setting		Maximum Allowable Downstream Pressure		Maximum Inlet Pressure to Keep Maximum Allowable Downstream Pressure from Being Exceeded ²					
					R627					
					Port Diameter, inches					
PSIG	BAR	PSIG	BAR	3/32	1/8	3/16	1/4	3/8	1/2	
15 to 40 PSIG (1.0 to 2.8 BAR)	15	1.0	60	4.1	1000	380	210	130	80	65
			100	6.9	2000	1300	590	350	170	120
			125	8.6	2000	1800	800	470	220	160
			175	12.1	2000	2000	1100	640	320	220
			200	13.8	2000	2000	1300	780	370	260
			250	17.2	2000	2000	1600	960	450	320
	20	1.4	60	4.1	630	200	150	100	70	65
			100	6.9	2000	1200	550	330	160	120
			125	8.6	2000	1700	760	450	210	160
			175	12.1	2000	2000	1100	630	320	220
			200	13.8	2000	2000	1300	770	360	260
			250	17.2	2000	2000	1600	960	450	320
	30	2.1	100	6.9	2000	950	450	260	140	110
			125	8.6	2000	1500	670	400	190	150
			175	12.1	2000	2000	1000	610	300	220
			200	13.8	2000	2000	1200	760	360	260
250			17.2	2000	2000	1600	970	450	320	
100			6.9	1500	700	330	200	120	108	
40	2.8	125	8.62	2000	1300	560	340	180	140	
		175	12.1	2000	1800	1000	550	290	220	
		200	13.8	2000	2000	1200	730	350	250	
		250	17.2	2000	2000	1600	970	460	320	

1. The internal relief performance values are obtained by removing the disk assembly.
 2. For inlet pressure in excess of 1000 PSIG (69.0 BAR) refer to the maximum body and disk pressure ratings in the specifications section.
 3. For pressure settings under 10 PSIG (0.69 BAR) inlet pressure should be limited to approximately 100 PSIG (6.90 BAR) so the set point adjustment can be obtained.
 4. Shaded areas indicate maximum inlet pressures allowed during system failure only.

R627 Internal Relief Performance¹

Outlet Pressure Spring Range	Outlet Pressure Setting		Maximum Allowable Downstream Pressure		Maximum Inlet Pressure to Keep Maximum Allowable Downstream Pressure from Being Exceeded ²					
					R627					
					Port Diameter, inches					
PSIG	BAR	PSIG	BAR	3/32	1/8	3/16	1/4	3/8	1/2	
35 to 80 PSIG (2.4 to 5.5 BAR)	40	2.8	125	8.6	2000	1100	500	300	170	140
			150	10.3	2000	1600	750	440	230	180
			175	12.1	2000	2000	980	580	290	220
			200	13.8	2000	2000	1200	720	340	250
			250	17.2	2000	2000	1600	940	450	320
	50	3.4	125	8.6	1400	820	400	230	150	140
			150	10.3	2000	1400	650	370	210	170
			175	12.1	2000	1900	700	530	270	210
			200	13.8	2000	2000	1100	670	330	240
			250	17.2	2000	2000	1500	920	430	320
	60	4.1	125	8.6	900	450	270	190	140	130
			150	10.3	1700	1100	540	300	190	160
175			12.1	2000	1700	780	470	250	200	
200			13.8	2000	2000	1000	610	310	230	
250			17.2	2000	2000	1400	880	420	310	
70	4.8	150	10.3	1200	850	430	250	170	160	
		175	12.1	2000	1400	670	400	230	190	
		200	13.8	2000	2000	920	550	280	230	
		250	17.2	2000	2000	1300	830	400	310	
		150	10.3	800	500	300	200	160	150	
80	5.5	175	12.1	1500	1200	550	330	210	190	
		200	13.8	2000	1700	800	480	270	220	
		250	17.2	2000	2000	1200	770	390	300	
		175	12.1	1900	600	400	260	200	175	
		200	13.8	2000	1200	630	380	250	210	
70 to 150 PSIG (4.8 to 10.3 BAR)	70	4.8	250	17.2	2000	2000	1100	680	360	290
			175	12.1	1400	250	240	200	190	175
			200	13.8	2000	960	250	330	240	210
	80	5.5	250	17.2	2000	2000	1000	620	350	280
			200	13.8	1500	250	240	230	210	210
			250	17.2	2000	1600	770	520	320	270
	125	8.6	250	17.2	2000	1000	500	390	290	260
	150	10.3	250	17.2	1200	260	260	260	260	260

1. The internal relief performance values are obtained by removing the disk assembly.
2. For inlet pressure in excess of 1000 PSIG (69.0 BAR) refer to the maximum body and disk pressure ratings in the specifications section.
3. For pressure settings under 10 PSIG (0.69 BAR) inlet pressure should be limited to approximately 100 PSIG (6.90 BAR) so the set point adjustment can be obtained.
4. - Shaded areas indicate maximum inlet pressures allowed during system failure only.

R627 Capacities for 3/4-inch Body Size¹

Outlet Pressure Spring Range	Outlet Pressure Setting		Inlet Pressure		Capacities in SCFH (Nm ³ /h) of 0.6 Specific Gravity Natural Gas 3/4" Body Size					
					Orifice Size, Inches					
					3/32	1/8	3/16	1/4	3/8	1/2
PSIG	BAR	PSIG	BAR	3/32	1/8	3/16	1/4	3/8	1/2	
5 to 20 PSIG ² (.03 to 1.4 BAR)	5	0.3	10	0.7	170	320	710	1050	1500	1850
			15	1.0	240	330	810	1290	2100	2850
			20	1.4	290	460	1090	1750	2750	3850
			30	2.1	380	610	1470	2490	3600	4800
			60	4.1	640	1170	2460	3690	5270	6120
			75	5.2	770	1410	2880	4150	5760	6900
			100	6.9	990	1690	3540	4790	6200	7600
			15	1.0	210	320	800	1290	2100	2820
			20	1.4	280	450	1070	1740	2700	3800
			30	2.1	380	610	1470	2430	3550	4780
	60	4.1	640	1170	2460	3690	5270	6120		
	75	5.2	770	1410	2880	4150	5760	6900		
	100	6.9	990	1690	3540	4790	6200	7600		
	150	10.3	1420	2430	4000	5680	6250	7630		
	200	13.8	1850	3070	4200	6200	6380	7680		
	300	20.7	2700	3970	4270	6250	6500			
	500	34.5	4010	4240	5640	6520				
	750	51.7	4400	5120	6400					
	1000	69.0	4450	6220						
	1250	86.2	4540							
	1500	103	4880							
	1750	121	5230							
	2000	138	5900							
	15 to 40 PSIG (1.0 to 2.8 BAR)	40	2.8	30	2.1	350	590	1390	2480	4350
50				3.5	550	980	2240	4000	7450	8000
60				4.1	640	1170	2610	4680	7800	8900
100				6.9	990	1800	3980	6700	9750	10400
150				10.3	1420	2580	5600	8790	10000	10800
200				13.8	1850	3370	7050	9000	10200	10800
300				20.7	2700	4910	7300	9500	10500	
500				34.5	4400	5200	7400	9760		
750				51.7	6600	5360	8870			
1000				69.0	7300	6500				
1250				86.2	7500					
1500				130	7800					
1750				121	8400					
2000				138	8600					
35 to 80 PSIG (2.4 to 5.5 BAR)	60	4.1	75	5.2	700	1230	2760	4700	8170	12600
			100	6.9	970	1740	3910	6690	11900	14400
			150	10.3	1420	2580	5850	9740	15700	18700
			200	13.8	1850	3370	7630	12400	18400	21200
			300	20.7	2700	4910	11200	17700	20200	
			500	34.5	4400	8090	18300	20000		
			750	51.7	6600	12000	18900	21400		
			1000	69.0	8700	16000	19000			
			1250	86.2	11000	18700				
			1500	130	13000	19000				
			1750	121	15000	20000				
			2000	138	17000					

Table Continued

1. Capacity is based on 20% droop unless otherwise noted below.
2. For pressure setting under 10 PSIG (06.9 BAR) inlet pressure should be limited to approximately 100 PSIG (6.90 BAR) so that setpoint adjustment can be obtained.
3. - Blank areas indicate where maximum operating inlet pressure for a given orifice is exceeded.

R627 Capacities for 3/4-inch Body Size¹

Outlet Pressure Spring Range	Outlet Pressure Setting		Inlet Pressure		Capacities in SCFH (Nm ³ /h) of 0.6 Specific Gravity Natural Gas 3/4" Body Size								
					Orifice Size, Inches								
	PSIG	BAR	PSIG	BAR	3/32	1/8	3/16	1/4	3/8	1/2			
35 to 80 PSIG (2.4 to 5.5 BAR)	80	5.5	100	6.90	900	1630	3570	6490	12000	17200			
			150	10.3	1410	2580	5780	10500	18900	25000			
			200	13.8	1850	3370	7630	13700	23000	29000			
			300	20.7	2700	4910	11200	20100	26000				
			500	34.5	4400	8090	18300	29000					
			750	51.7	6600	12000	23100	30900					
			1000	69.0	8700	16000	27400						
			1250	86.2	11000	19000							
			1500	130	13000	22000							
			1750	121	15000	25000							
			2000	138	17000								
			70 to 150 PSIG (4.8 to 10.3 BAR)	100	6.9	150	10.3	1170	2510	5540	8310	15500	20300
						200	13.8	1850	3370	7630	12000	20100	25700
300	20.7	2700				4910	11200	18200					
500	34.5	4400				8090	18300						
750	51.7	6600				12000							
1000	69.0	8700				16000							
1250	86.2	11000											
1500	130	13000											
1750	121	15000											
2000	138	17000											
125	8.6	150		10.3	1250	2330	5090	9130	15700	20800			
		200		13.8	1830	3320	7360	13160	22400	28600			
		300		20.7	2700	4910	11200	19700					
		500		34.5	4400	8090	18300						
		750		51.7	6600	12000							
		1000		69.0	8700	16000							
		1250		86.2	11000								
		1500		130	13000								
		1750		121	15000								
		2000		138	17000								
150	10.3	200	13.8	1760	3200	7020	12500	21400	30600				
		300	20.7	2700	4910	11200	17200						
		500	34.5	4400	8090	18300							
		750	51.7	6600	12000								
		1000	69.0	8700	16000								
		1250	86.2	11000									
		1500	130	13000									
		1750	121	15000									
		2000	138	17000									

1. Capacity is based on 20% droop unless otherwise noted below.
2. For pressure setting under 10 PSIG (06.9 BAR) inlet pressure should be limited to approximately 100 PSIG (6.90 BAR) so that setpoint adjustment can be obtained.
3. [Blank] - Blank areas indicate where maximum operating inlet pressure for a given orifice is exceeded.

R627 Capacities for 1 and 2 Inch Body Sizes¹

Outlet Pressure Spring Range	Outlet Pressure Setting		Inlet Pressure		Capacities in SCFH (Nm ³ /h) of 0.6 Specific Gravity Natural Gas 1 & 2" Body Size					
					Orifice Size, Inches					
	PSIG	BAR	PSIG	BAR	3/32	1/8	3/16	1/4	3/8	1/2
5 to 20 PSIG ² (.03 to 1.4 BAR)	5	0.3	10	0.7	170	330	710	1080	2000	2150
			15	1.0	240	390	890	1500	2350	3000
			20	1.4	290	500	1160	1900	2750	3900
			30	2.0	380	690	1500	2500	3600	4900
			60	4.1	640	1170	2460	3690	5650	6900
			75	5.2	770	1410	2880	4150	6450	7490
			100	6.9	990	1800	3540	5790	7520	8150
			15	1.0	210	390	840	1480	2300	2930
			20	1.4	280	500	1100	1880	2700	3830
			30	2.0	380	690	1500	2460	3550	4840
	60	4.1	640	1170	2460	3690	5650	6900		
	75	5.2	770	1410	2880	4150	6450	7490		
	100	6.9	990	1800	3540	4790	7520	8150		
	150	10.3	1420	2580	4660	5680	9980	10800		
	200	13.8	1850	3370	5620	6360	11000	12900		
	300	20.7	2700	4880	6890	7780	13600			
	500	34.5	4400	6720	8570	11600				
	750	51.7	5400	8850	9000					
	1000	69.0	5800	9500						
	1250	86.2	6300							
1500	103	6600								
1750	121	6800								
2000	138	7600								
20	1.4	30	2.07	350	600	1390	2580	4350	6290	
		50	3.45	550	1000	2250	4090	7600	8000	
		60	4.14	640	1170	2630	4750	7800	10600	
		100	6.90	990	1800	4070	7310	10800	13400	
		150	10.3	1420	2580	5720	10300	13500	14000	
		200	13.8	1850	3370	7050	10500	14000	14000	
		300	20.7	2700	4910	9250	10800	14900		
		500	34.5	4400	7830	11800	13000			
		750	51.7	6600	9000	12000				
		1000	69.0	8700	9660					
1250	86.2	10000								
1500	103	10400								
1750	121	12000								
2000	138	14000								
15 to 40 PSIG (1.0 to 2.8 BAR)	40	2.8	60	4.1	610	1090	2430	4510	9200	9400
			75	5.2	760	1370	3080	5640	10800	16300
			100	6.9	990	1790	4070	7310	13500	17600
			150	10.3	1420	2580	5850	10500	18000	22200
			200	13.8	1850	3370	7630	11000	21400	24600
			300	20.7	2700	4910	11200	14900	24400	
			500	34.5	4400	8090	16300	21800		
			750	51.7	6600	12000	20200	23600		
			1000	69.0	8700	16000	23200			
			1250	86.2	11000	19000				
1500	103	13000	21000							
1750	121	15000								
2000	138	17000								
35 to 80 PSIG (2.4 to 5.5 BAR)	60	4.1	75	5.2	700	1230	2760	4860	8600	12800
			100	6.9	970	1740	3910	7000	12500	16700
			150	10.3	1420	2580	5850	10500	16800	2300
			200	13.8	1850	3370	7630	13700	20900	27700
			300	20.7	2700	4910	11200	20100	28100	
			500	34.5	4400	8090	18300	28500		
			750	51.7	6600	12000	22800	29500		
			1000	69.0	8700	16000	26800			
			1250	86.2	11000	19000				
			1500	103	13000	22000				
1750	121	15000	25000							
2000	138	17000								

Table Continued

1. Capacity is based on 20% droop unless otherwise noted below.
2. For pressure setting under 10 PSIG (06.9 BAR) inlet pressure should be limited to approximately 100 PSIF (6.90 BAR) so that setpoint adjustment can be obtained.
3. [Blank] - Blank areas indicate where maximum operating inlet pressure for a given orifice is exceeded.

R627 Capacities for 1 and 2 Inch Body Sizes¹

Outlet Pressure Spring Range	Outlet Pressure Setting		Inlet Pressure		Capacities in SCFH (Nm ³ /h) of 0.6 Specific Gravity Natural Gas 1 & 2" Body Size						
					Orifice Size, Inches						
	PSIG	BAR	PSIG	BAR	3/32	1/8	3/16	1/4	3/8	1/2	
35 to 80 PSIG (2.4 to 5.5 BAR)	80	5.5	100	6.9	900	1630	3570	6650	12000	17400	
			150	10.3	1410	2580	5750	10500	20100	26000	
			200	13.8	1850	3370	7630	13700	25100	31800	
			300	20.7	2700	4910	11200	20100	32600		
			500	34.5	4400	8090	18300	30300			
			750	51.7	6600	12000	27200	37400			
			1000	69.0	8700	16000	33300				
			1250	86.2	11000	19000					
			1500	103	13000	22000					
			1750	121	15000	25000					
2000	138	17000									
70 to 100 PSIG (4.8 to 6.9 BAR)	100	6.9	150	10.3	1170	2510	5540	8310	15500	20300	
			200	13.8	1850	3370	7630	12000	20100	26700	
			300	20.7	2700	4910	11200	18200			
			500	34.5	4400	8090	18300				
			750	51.7	6600	12000					
			1000	69.0	8700	16000					
			1250	86.2	11000						
			1500	103	13000						
			1750	121	15000						
			2000	138	17000						
70 to 150 PSIG (4.8 to 10.3 BAR)	125	8.6	150	10.3	1250	2330	5090	9470	15700	20800	
			200	13.8	1830	3320	7360	13400	23600	31300	
			300	20.7	2700	4910	11200	19700			
			500	34.5	4400	8090	18300				
			750	51.7	6600	12000					
			1000	69.0	8700	16000					
			1250	86.2	11000						
			1500	103	13000						
			1750	121	15000						
			2000	138	17000						
150 to 200 PSIG (10.3 to 13.8 BAR)	150	10.3	200	13.8	1760	3200	7020	12900	21400	33300	
			300	20.7	2700	4910	11200	17200			
			500	34.5	4400	8090	18300				
			750	51.7	6600	12000					
			1000	69.0	8700	16000					
			1250	86.2	11000						
			1500	103	13000						
			1750	121	15000						
			2000	138	17000						

1. Capacity is based on 20% droop unless otherwise noted below.
 [Blank area] - Blank areas indicate where maximum operating inlet pressure for a given orifice is exceeded.

R627 Parts

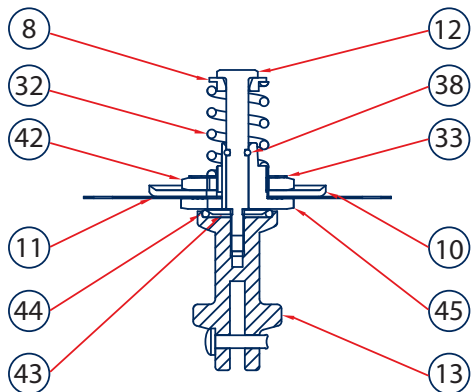
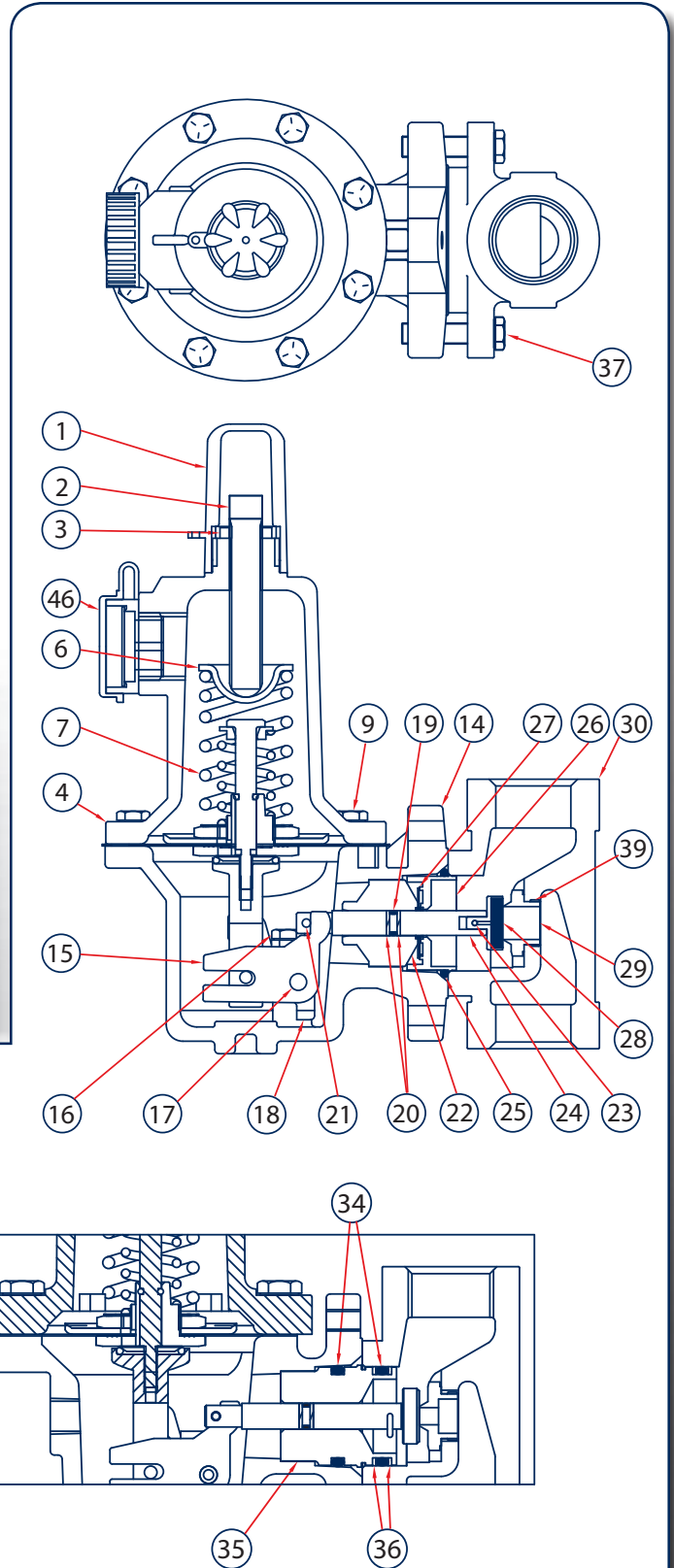

R627 Parts

Item	Description	Qty.	Part Number
1	Cover Adj. Screw, Plastic	1	610-053-000
2	Adjustment Screw	1	648-520-000
3	Locknut	1	634-154-000
4	Bonnet, R627 - Aluminum	1	604-210-000
	Bonnet, R627M - Steel		604-211-000
	Bonnet, R627 - Stainless		604-266-000
5	Vent Screw Assembly	1	836-005-000
6	Spring Guide, Upper	1	626-079-000
7	Range Spring	1	
	5-20 PSIG–Yellow		655-661-000
	15-40 PSIG–Green		655-661-001
	35-80 PSIG & 10-95–PSIG Blue		655-661-002
	70-150 PSIG–Red		655-661-003
	140-250 PSIG–Blue		655-661-002
240-500 PSIG–Red	655-661-003		
8	Spring Guide, Lower (R627 or R627M only)	1	626-101-000
9	Al Spring Case Screws - R627	8	648-466-000
	Stl Spring Case Screws - R627 or R627M		648-467-003
	SS Spring Case Screws - R627 or R627M		648-550-000
10	Diaphragm Piston (R627 or R627M only)	1	637-322-000
11	Diaphragm R627 & R627M Aluminum / Iron Case	1	618-079-000
	Diaphragm R627 & R627M Steel Case		618-080-000
	Diaphragm R627 & R627M Al / Iron (Fluoro)		618-080-001
	Diaphragm R627 & R627M Steel (Fluoro)		618-079-001
12	Diaphragm Retainer	1	648-521-000
13	Post, Pusher R627 & R627M Assy	1	827-011-000
14	Diaphragm Case R627 - Aluminum	1	629-202-000
	Diaphragm Case R627 - Steel		629-203-000
	Diaphragm Case R627M - Steel		629-204-000
	Diaphragm Case, Aluminum (for Steel Body)		629-215-000
	Diaphragm Case R627 - Stainless		629-242-000
	Diaphragm Case R627M - Stainless		629-243-000
15	Lever	1	703-004-000
	Lever, NACE		703-005-000
16	Lever Screw	2	648-466-002
	Lever Screw, NACE		648-474-000
17	Pin, Lever	1	635-053-000
	Pin, Lever, NACE		635-057-000
18	Lever Retainer	1	643-192-000
	Lever Retainer, NACE		643-194-000
19	Stem O-ring, Nitrile	1	649-000-003
	Stem O-ring, Fluorocarbon		649-000-343
20	Stem Backup Ring, TFE	2	644-047-000
21	Pin, Groove	1	635-054-000
	Pin, Groove NACE		635-058-000
22	Stem Guide	1	626-083-000
23	Pin Clip	1	635-055-000
	Pin Clip NACE		635-056-000
24	Stem, 316SS	1	689-005-000
25	Diaphragm Case O-ring, Nitrile (R627 & R627H)	1	649-280-000
	Diaphragm Case O-ring, Fluorocarbon (R627 & R627H)		649-280-001
26	Boost Body R627	1	686-004-000
27	Stabilizer, Nitrile R627	1	649-278-000
	Stabilizer, Fluorocarbon R627		649-278-001

Item	Description	Qty.	Part Number
28	Seat assembly - Aluminum holder/nitrile disk	1	822-019-000
	Seat assembly - Aluminum/nylon		822-019-001
	Seat assembly - Aluminum/Fluorocarbon		822-040-000
	Seat assembly - 316SS Holder/Nitrile		822-020-000
	Seat assembly - 316SS/Nylon		822-020-001
	Seat assembly - 316SS/Fluorocarbon		822-040-001
29	Orifice - Aluminum - 3/32"	1	688-013-005
	Orifice - Aluminum - 1/8"		688-013-004
	Orifice - Aluminum - 3/16"		688-013-003
	Orifice - Aluminum - 1/4"		688-013-002
	Orifice - Aluminum - 3/8"		688-013-001
	Orifice - Aluminum - 1/2"		688-013-000
	Orifice - 316SS - 3/32"		688-014-005
	Orifice - 316SS - 1/8"		688-014-004
	Orifice - 316SS - 3/16"		688-014-003
	Orifice - 316SS - 1/4"		688-014-002
	Orifice - 316SS - 3/8"		688-014-001
	Orifice - 316SS - 1/2"		688-014-000
30	Iron Body - 3/4 NPT	1	664-280-000
	Iron Body - 1 NPT		664-280-001
	Iron Body - 2 NPT		664-282-000
	Steel Body - 3/4 NPT		664-281-000
	Steel Body - 1 NPT		664-281-001
	Steel Body - 2 NPT		664-283-000
	LCC Body - 3/4 NPT		664-325-000
	LCC Body - 1 NPT LCC		664-325-001
	LCC Body - 2 NPT LCC		664-326-000
	Stainless Body - 3/4 NPT		664-394-000
	Stainless Body - 1 NPT		664-394-001
	Stainless Body - 2 NPT		664-395-000
	Steel - 3/4 NPT Socket Weld		664-356-000
	Steel - 1 NPT Socket Weld		664-358-000
Steel - 2 NPT Socket Weld	664-359-000		
Stainless - 3/4" Socket Weld	664-422-000		
Stainless - 1" Socket Weld	664-423-000		
Stainless - 2" Socket Weld	664-424-000		
31	Nameplate (not shown)	1	632-474-000
32	Relief Spring	1	655-709-000
33	Lower Spring Seat	1	626-102-000
34	O-ring, Throat Block, Nitrile	2	649-281-000
	O-ring, Throat Block, Fluorocarbon		649-281-001
35	Throat Block (R627M only)	1	626-081-000
36	Backup Ring, Throat Block	2	644-048-000
37	Build Screw, 3/4" & 1" Aluminum unit	2	648-466-001
	Build Screw 2" Aluminum unit		648-466-003
	Build Screw, all Steel Bodies		648-467-001
	Build Screw, all Stainless Bodies		648-549-000
38	O-ring, Nitrile	1	649-000-001
	O-ring, Fluorocarbon		649-000-226
40	Name Plate Drive Screw (not shown)	2	648-464-000
41	NACE Tag (not shown)	1	632-503-000
42	Diaphragm Connecting Nut	1	634-182-000
43	Relief Seal Retainer	1	643-198-000
44	Relief Seal O-ring, Nitrile	1	649-308-000
	Relief Seal O-ring, Fluorocarbon		649-308-001
45	Diaphragm Connector	1	650-150-000
46	Relief Cap	1	614-064-000