

“TUBE TEMP”

Series 1830R

- Patented “Knife-Edge” Thermojunction
- More Accurate than Pad Type Thermocouple
- Most Commonly Used Design with Expansion Loop
- Ideal for Applications where Tube Movement is Greater than 3"
- Best Value for Accuracy and Longevity
- Wrap Around Angle 90° “W”
- Retaining Clip Furnished, Clip Material Matches Sheath Material

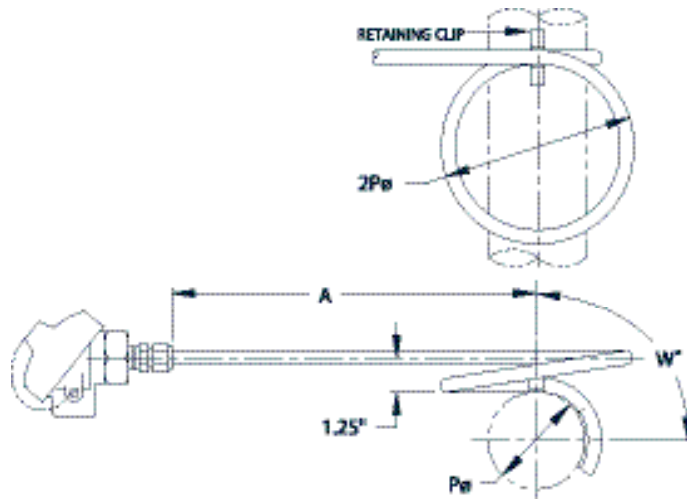

Enter a selection for each item, please fax your inquiry to TCP.

Example: 1830R - K - 36 - 6.625 - 90 - G - 446 - CI - 0 - 0

1830R - - - - - - - - -

CODE	WIRE CALIBRATION
E	Chromel/Constantan
J	Iron/Constantan
K	Chromel/Alumel
EE	Duplex Chromel/Constantan
JJ	Duplex Iron/Constantan
KK	Duplex Chromel/Alumel
Consult factory for other calibrations	
Type K is standard	

LENGTH “A”
Specify “A” dimension in inches (above). See page 152 for “A” dimension if spring loaded cover plate is needed.

HEATER TUBE DIAMETER “P”
Specify “P” dimension in inches. Actual tube outside diameter is required. (3.5" min.)

WRAP AROUND ANGLE “W”
90 90° (Standard)
Specify other angles in degrees.

CODE	OTHER PERTINENT DATA
0	NONE
999	Special Consult Factory

CODE	SPRING LOADED COVER PLATE
0	None
S809	Spring Loaded
None is Standard	

CODE	HEAD
0	None
CI	Cast Iron
AL	Aluminum
Cast Iron is standard	

CODE	SHEATH MATERIAL
310	310 Stainless Steel
446	446 Stainless Steel
HAX	Hastelloy X
446SS is standard	
Hastelloy material has a thinner wall thickness.	

CODE	JUNCTION STYLE
G	Grounded Junction
U	Ungrounded Junction
Grounded Junction is standard	

Metric Orders Welcome

Place an **mm** in the appropriate selection box: