

P630R High Flow Gas Relief Valve



- Stainless Steel Internals are Standard
- Steel Units comply with NACE MR0175
- Durable Powder Coated Exterior
- High Flow Capacities

Applications

- Compressor Stations
- Refineries
- High Pressure Plants

The BelGAS P630R is a spring loaded, adjustable relief valve designed for relief pressure settings from 3 PSIG to 250 PSIG (0.21 to 17.3 BAR). The heavy duty construction, made possible by the addition of stainless steel internal components and a powder-coated epoxy exterior finish, makes it ideally suited for the oil and gas industries. All P630 steel units meet NACE MR0175 material requirements for corrosive (sour gas) environments.

Materials of Construction

Body, Bonnet	Cast Iron
	Steel (1030 WCB)
Diaphragm	Neoprene
	Fluorocarbon
Seat	Nitrile
Orifice	316 Stainless Steel



P630R Part Matrix

P630R		8 0			
	08			Body Size	1"
	16				2"
				Spring Range	
				PSIG	BAR
	008			3 - 8	0.21 - 0.55
	017			6 - 17	0.41 - 1.17
	022			15 - 22	1.02 - 1.52
	035			20 - 35	1.38 - 2.41
	050			35 - 50	2.41 - 3.45
	070			30 - 70	2.1 - 4.8
	095			50 - 95	3.4 - 6.6
	175			75 - 175	5.2 - 12.1
	250			150 - 250	10.3 - 17.2
				Standard NPT Units	
				Flanged Connections	
				150 # RF*	*Steel Units Only
				300 # RF*	
				600 # RF*	
				Diaphragm	
			2	Fluorocarbon	
			3	Neoprene	
				Casing Material	
			0	Cast Iron	
			1	Steel	

Specifications

Maximum Allowable Relief Inlet	Relief Pressure Setting Plus 250 PSIG	
Outlet	3-250 PSIG	
Body Sizes	1 NPT	
	2 NPT	
Outlet Ranges		
	3 - 8 PSIG	Low Pressure
	6 - 17 PSIG	
	15 - 22 PSIG	
	20 - 35 PSIG	
	35 - 50 PSIG	
	30 - 70 PSIG	High Pressure
	50 - 95 PSIG	
	75 - 175 PSIG	
	150 - 250 PSIG	
Temp. Range	-20° to 150°F	-29° to 66°C
Orifice Size	1/2"	
Weight Approximate		
1"	20 lbs	9 kg
2"	25 lbs	11.25 kg

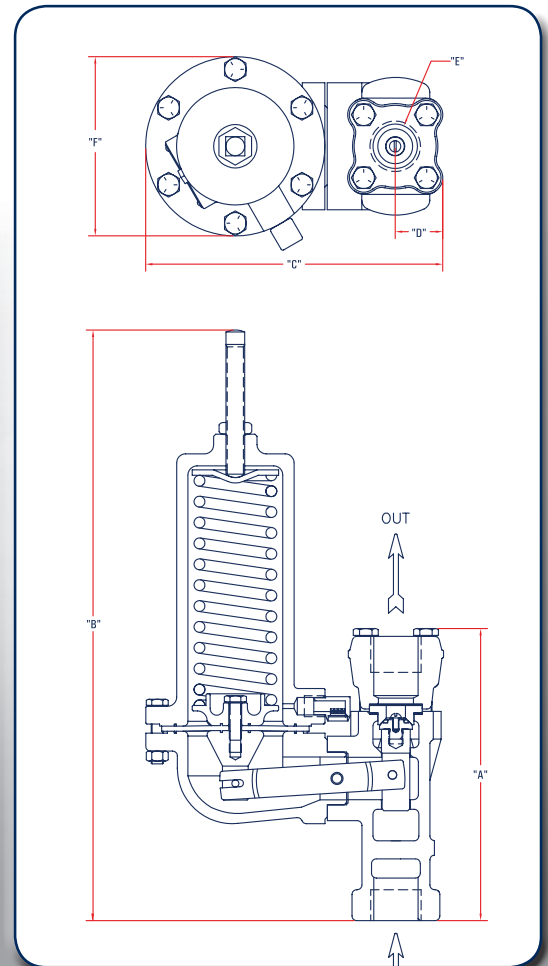

		Body Size	A	B	C	D	E	F
1" P630R	High Pressure	mm	193	391	198	29	1"	119
	Low Pressure	inches	7.61	15.39	7.79	1.15	NPT	4.67
2" P630R	High Pressure	mm	211	398	215	45	2"	119
	Low Pressure	inches	8.31	15.66	8.45	1.90	NPT	4.67
1" P630R	High Pressure	mm	193	391	231	29	1"	184
	Low Pressure	inches	7.61	15.39	9.09	1.15	NPT	7.25
2" P630R	High Pressure	mm	211	398	248	45	2"	184
	Low Pressure	inches	8.31	15.66	9.75	1.90	NPT	7.25

P630R Parts

Item	Description	Part Number	
1	Nameplate (requires 4 drive screws for mounting)	632-472-000	
2	Drive Screw (4 required)	648-464-000	
3	Adjusting Screw	Spring Ranges	
		3-8 PSIG	648-462-002
		6-17 PSIG	648-462-001
		15-22 PSIG	648-462-000
		20-35 PSIG	648-462-003
		35-50 PSIG	648-462-003
		30-70 PSIG	648-462-001
		50-95 PSIG	648-462-000
		75-175 PSIG	648-462-003
150-250 PSIG	648-462-003		
4	Hex Nut	634-000-056	
5	Upper Spring Guide	Pressure Ranges: 3-8, 6-17, 15-22, 20-35, & 30-70, 50-95 & 75-175 PSIG	626-077-000
		Pressure Ranges: 35-50 & 150-250 PSIG	626-078-000
6	Bonnet - Iron (30-70 PSIG thru 150-250 PSIG)		604-204-000
	Bonnet - Steel (30-70 PSIG thru 150-250 PSIG)		604-205-000
	Bonnet - Iron (3-8 PSIG thru 35-50 PSIG)		604-233-000
	Bonnet - Steel (3-8 PSIG thru 35-50 PSIG)		604-234-000
7	Range Spring	3-8 PSIG	655-659-000
		6-17 PSIG	655-659-001
		15-22 PSIG	655-659-002
		20-35 PSIG	655-659-003
		35-50 PSIG	655-659-004
		30-70 PSIG	655-659-001
		50-95 PSIG	655-659-002
		75-175 PSIG	655-659-003
150-250 PSIG	655-659-004		
8	Diaphragm Screw	648-463-000	
9	Lower Spring Guide	3-8 PSIG	626-095-000
		6-17 PSIG	
		15-22 PSIG	
		20-35 PSIG	
		35-50 PSIG	637-304-000
		30-70 PSIG	
		50-95 PSIG	
		75-175 PSIG	
150-250 PSIG	637-305-000		
10	Pressure Ranges: 3-8, 6-17, 15-22, 20-35, & 35-50 PSIG		
	Diaphragm	Neoprene	618-073-000
		Fluorocarbon (2 required)	618-073-001
	Pressure Ranges: 30-70, 50-95, 75-175, & 150-250 PSIG		
Diaphragm	Neoprene	618-068-000	
	Fluorocarbon (2 required)	618-068-001	
11	Hex nut for the iron diaphragm housing	Pressure Ranges: 3-8, 6-17, 15-22, 20-35, & 35-50 PSIG (10 Required)	634-000-112
		Pressure Ranges: 30-70, 50-95, 75-175, & 150-250 PSIG (4 Required)	

Item	Description	Part Number	
12	Build Screws	For the Iron Diaphragm Housing Ranges: 3-8, 6-17, 15-22, 20-35, & 35-50 PSIG (10 Required)	648-463-003
		For the Steel Diaphragm Housing Ranges: 3-8, 6-17, 15-22, 20-35, & 35-50 PSIG (10 Required)	648-463-007
		For the Iron Diaphragm Housing Ranges: 30-70, 50-95, 75-175, & 150-250 PSIG (4 Required)	648-463-003
		For the Steel Diaphragm Housing Ranges: 30-70, 50-95, 75-175, & 150-250 PSIG (4 Required)	648-463-005
13	Connector piston assembly Aluminum trim, NACE		827-006-000
	Connector piston assembly Stainless Steel trim, NACE		827-006-001
14	Diaphragm Housing	Iron (Ranges: 3-8, 6-17, 15-22, 20-35, & 35-50 PSIG)	629-224-000
		Steel (Ranges: 3-8, 6-17, 15-22, 20-35, & 35-50 PSIG)	629-225-000
		Iron (Ranges: 30-70, 50-95, 75-175, & 150-250 PSIG)	629-199-000
		Steel (Ranges: 30-70, 50-95, 75-175, & 150-250 PSIG)	629-200-000
15	Lever Assembly	(Ranges: 3-8, 6-17, 15-22, 20-35, & 35-50 PSIG)	827-010-000
		(Ranges: 30-70, 50-95, 75-175, & 150-250 PSIG)	827-003-000
		NACE units only (Ranges: 30-70, 50-95, 75-175, & 150-250 PSIG)	827-007-000
16	Pin	635-052-000	
17	Gasket - Composite	624-056-000	
18	Build screw	1" body (4 required)	648-463-004
		2" body (4 required)	648-463-006
19	Inlet adapter	1 NPT 1030 Carbon Steel	679-036-000
		2 NPT 1030 Carbon Steel	679-037-000
20	Body	1 NPT Iron	805-308-001
		1 NPT Steel	805-308-000
		2 NPT Iron	664-277-000
		2 NPT Steel	664-279-000
21	Body Gaskets Composite (2 required)	624-058-000	
22	Orifice 1/2"	650-126-000	
23	Seat Housing, SS	629-214-000	
24	Valve Carrier	673-017-000	
25	Build screw for steel diaphragm housing (2 required)	648-463-001	
26	Vent protector assembly	836-004-000	
27	Cap screws (Body to Housing) not shown	648-463-002	
28	O-ring, Nitrile		649-292-000
	O-ring, Fluorocarbon		649-300-000
29	Housing Screw	648-486-000	
30	Housing Plate	638-064-000	

P630R High Flow Gas Relief Valve

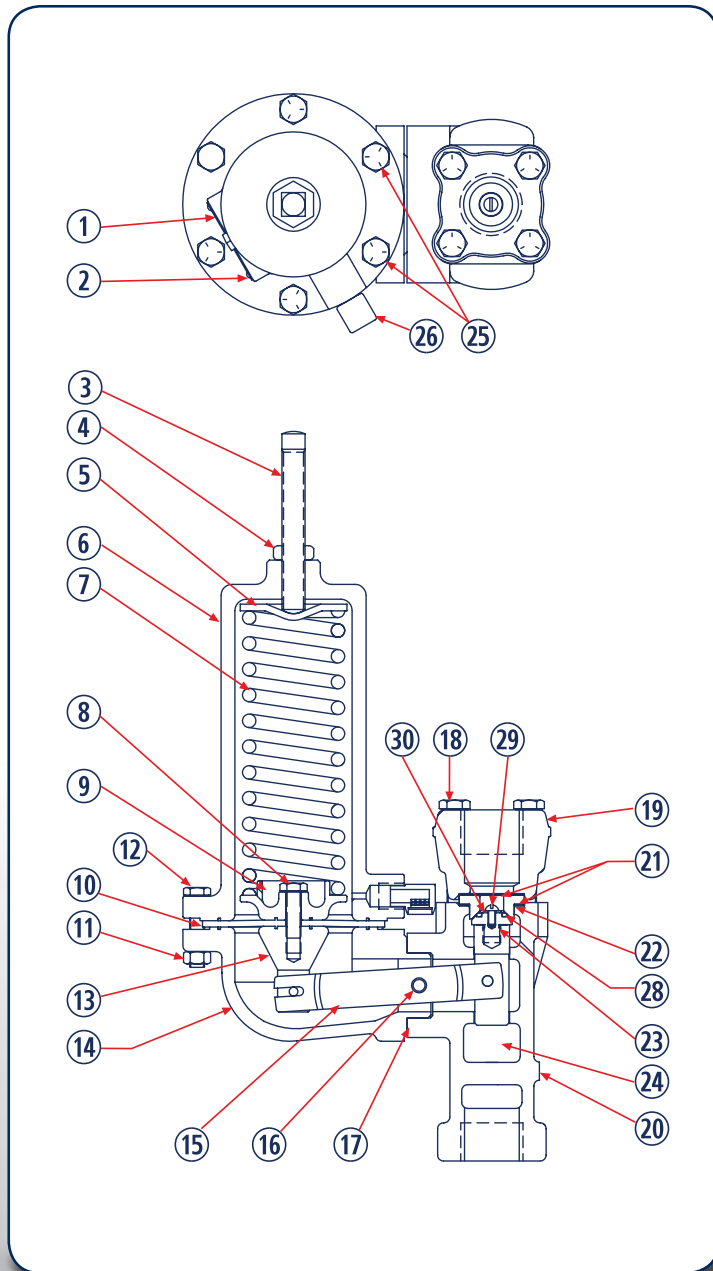

Relief Capacity Table - P630R High Pressure

Initial Relief Pressure Setting		Capacities, SCFH of 0.6 S.G. Natural Gas	
		10% Pressure Increase	20% Pressure Increase
PSIG	BAR	SCFH	SCFH
50	3.4	2900	7100
75	5.2	2700	7480
250	6.9	3260	9670
125	8.6	5500	14,200
175	12.1	5480	19,000
250	17.2	13,500	48,000

Note: Maximum working pressure above setting is 250 PSIG (17.2 BAR)

Relief Capacity Table - P630R Low Pressure

Initial Relief Pressure Setting		Capacities, SCFH of 0.6 S.G. Natural Gas	
		10% Pressure Increase	20% Pressure Increase
PSIG	BAR	SCFH	SCFH
5	0.35	640	2710
10	0.69	1420	2900
15	1.0	2000	4200
20	1.4	2130	4450
35	2.4	3030	7230
50	3.4	4900	14000

Note: Maximum working pressure above setting is 250 PSIG (17.2 BAR)

Spring Range

Spring Range	Adj. Screw (3)	Range Spring (7)	Spring Color Code
3 - 8 PSIG	648-462-002	655-659-000	Red Stripe
6 - 17 PSIG	648-462-001	655-659-001	Olive Drab
15 - 22 PSIG	648-462-000	655-659-002	Silver
20 - 35 PSIG	648-462-003	655-659-003	Green Stripe
35 - 50 PSIG	648-462-003	655-659-004	Blue Stripe
30 - 70 PSIG	648-462-001	655-659-001	Olive Drab
50 - 95 PSIG	648-462-000	655-659-002	Silver
75 - 175 PSIG	648-462-003	655-659-003	Green Stripe
150 - 250 PSIG	648-462-003	655-659-004	Blue Stripe

P630R Relief Valve Rebuild Kits

	Kit Includes	Part Number
Pressure Ranges: 30 - 70 PSIG thru 150-250 PSIG	Neoprene diaphragms, nitrile O-ring, seat housing assembly and 2 orifice gaskets	971-630-R00
Pressure Ranges: 30 - 70 PSIG thru 150-250 PSIG	Fluorocarbon diaphragms, fluorocarbon O-ring, seat housing assembly and 2 orifice gaskets	971-630-R01
Pressure Ranges: 3 - 8 PSIG thru 35 - 50 PSIG	Low pressure Neoprene diaphragm, nitrile O-ring, seat housing assembly and 2 orifice gaskets	971-630-R02
Pressure Ranges: 3 - 8 PSIG thru 35 - 50 PSIG	Low pressure fluorocarbon diaphragms, fluorocarbon O-ring, seat housing assembly and 2 orifice disks	971-630-R03

