

T2000 Explosion Proof I/P & E/P Transducers

- Field-selectable inputs and direct/reverse/split ranging
- Multiple input/output/mounting configurations
- Precise, reliable performance under extreme conditions of temperature, vibration, orientation, supply pressure changes, supply voltage changes, RFI/EMI, humid/oil-laden media, and corrosive surroundings

The T2000EX is a robust electronic instrument that regulates an incoming supply pressure down to a precise output pressure which is directly proportional to an electrical control signal. The secret to the T2000EX's precise, reliable performance under a variety of demanding environmental conditions is a patented piezo-ceramic actuator with many industry-wide firsts.

Applications

- Valve Actuators
- Valve Positioners
- Relay
- Controllers
- Chemical & Petrochemical Industries
- Petroleum Production
- Pipeline Transmission

Principle of Operation

The T2000EX I/P and E/P transducers utilize closed-loop pressure feedback-control for precision pressure output and minimized effects of temperature, supply pressure changes, supply voltage changes, and mounting angle.

Supply pressure is reduced by the supply valve to provide an output pressure which is internally routed to a precision temperature compensated piezo resistive pressure sensor. Supply pressure is also routed to an externally removable orifice which provides a reduced pilot pressure to a chamber containing a servo diaphragm and nozzle. Pilot pressure is controlled by modulating the gap between the face of a nozzle and an adjacent piezo-ceramic actuator, which is part of a unique patented mechanism.

The piezo-ceramic actuator serves as a control link between electrical input and pressure output as follows:

- The input current (I/P) or voltage (E/P) signal is conditioned to provide a normalized control signal directly proportional to the desired pressure output.
- Simultaneously the output of the pressure sensor is amplified and conditioned to produce a feedback signal.
- The sum of the control signal and the feedback signal produce a command signal which is delivered as a DC voltage to the piezo-ceramic actuator.
- As voltage increases, the force applied by the actuator increases, so as to restrict nozzle bleed and thus increase pilot pressure.
- Increased pilot pressure applied to the servo diaphragm directly causes opening of the supply valve and an increase in the output pressure until the output feedback signal and control signal combine to produce the correct command signal.

Air Quality

Instrument-quality air consists of

- a. A dew point less than 35°F
- b. No particles larger than three microns
- c. Maximum oil content of 1 ppm



Fine-Tuning Your Application

For optimal performance in your application, the calibration of the Type 2000EX can be fine-tuned in the field. An easily-removable cover provides access to the isolated electronics. All potentiometers, connections, jumpers, and switches are clearly marked on the circuit board or on the handy chart located on the inside of the cover. The three elements of calibration (Gain, Zero, and Span) are described below. Consult the T2000EX User's Manual for detailed calibration procedures, cautions, and instrumentation requirements.

Gain (Damping) Adjustment

The output response of the T2000EX can be optimized for varying downstream volumes by adjusting the system gain of the control circuit. Adjust the Gain Pot counterclockwise for increased gain; clockwise for increased oscillation damping. For maximum allowable gain in your application, the pot should be turned clockwise until oscillation just disappears.

Zero & Span Adjustments

The T2000EX contains multi-turn Coarse-Zero, Fine-Zero, and Span adjustment potentiometers which are clockwise positive. Adjustment of either Zero Pot changes the unit's minimum output while the Span Pot changes the maximum output. The adjustments are interactive, so it may take iterations to reach the desired calibration.

Wide Rangeability

The T2000EX can be field calibrated to pressure ranges other than the standard ones by combinations of recalibration, pressure range switching, and split high/low ranging. A unit should not be switched to a range outside its pressure sensor family (e.g., 0-15 PSIG can be switched to a 3-15 PSIG, but not to 0-30 PSIG). (Caution: Do not exceed the range of the onboard pressure sensor.) For example, the easiest way to recalibrate a 0-30 PSIG unit to 3-15 PSIG would be to change the switch setting to 3-27 PSIG, then switch to split range low.

Field-Selectable Features

Onboard switches allow the user to easily reconfigure the T2000EX for any of several electrical inputs, direct/reverse acting, or output split-ranging high/low. Fine tuning of the unit's calibration may be necessary after a reconfiguration.

Direct/Reverse Acting

Direct Acting transducers regulate to their minimum output when supplied with minimum input; maximum out with maximum in. Reverse Acting transducers regulate to their maximum output at minimum input.

Split Ranging-High & Low

The T2000EX can be configured to regulate either half (top or bottom) of it's normal output range, when supplied with it's normal full-ranging electrical input. For example, a 0-10V 0-30 PSIG unit set to split range low will regulate 0-15 PSIG @ 0-10V. It will regulate 15-30 PSIG @ 0-10V if set to split range high.

Hazardous Area &

Usage Classification

"F" model: Dual Listing of FM/CSA for following approvals:

Explosion Proof: Class I, Division 1, Groups A,B,C,D, T6 @ 60°C Max

Dust Ignition Proof: Class II, III, Division 1, Groups E,F,G; T6 @ 60°C Max

Intrinsic Safety: FM/CSA Class I II III, Division 1, Groups A,B,C,D,E,F,G, T4 @ 60°C Max

Non-incendive: Class I, Division 2, Groups A, B, C, D. T4 @ 60°C Max

Suitable for use in Class II III, Division 2, Groups F, G. T4 @ 60°C Max

Environmental rating: TYPE 4X, IP66

Note: Certified by FM, "F" model can be used in Natural Gas application in US and Canada, merely in a condition that a suitably rated NRTL listed or certified conduit seal is mandatory.

"G" model: Listing of FM for using Natural Gas as a process medium in US and Canada for following approvals:

Explosion Proof: Class I, Division 1, Groups A,B,C,D, T6 @ 60°C Max

Dust Ignition Proof: Class II, III, Division 1, Groups E,F,G; T6 @ 60°C Max

Intrinsic Safety: FM Class I II III, Division 1, Groups A,B,C,D,E,F,G T4 @ 60°C Max

Non-incendive: Class I, Division 2, Groups A, B, C, D. T4 @ 60°C Max

Suitable for use in Class II III, Division 2, Groups F, G. T4 @ 60°C Max

Environmental rating: TYPE 4X, IP66

CE: (Conduit Connector Only) EN 50081-1 Residential, commercial & light industry; EN-50082-2 Heavy Industrial.

T2000 Part Matrix

2K	E									00	
		↑	↑	↑	↑	↑	↑				Electrical Port
		N									1/2 NPT Conduit
											Pneumatic Ports
		N									NPT
		T									BSPT
		P									BSPP
		M									Manifold Mount*
											*Bottom O-Ring Ports
											Agency Approval
		F									FM/CSA
		G									FM Natural Gas Approval for US and Canada, includes factory conduit seal
											Electrical Input
			42								4-20 mA
			05								0-5 V
			15								1-5 V
			19								1-9 V
			11								1-10 V
			01								0-10 V
											Direct Acting
											Reverse Acting
											Pneumatic Output
											Full Range
											Split Range High
											Split Range Low
											Pressure Ranges
											PSIG
											BAR
											005
											0-5
											0-0.3
											015
											0-15
											0-1.0
											315
											3-15
											0.2-1.0
											117
											1-17
											0.07-1.2
											030
											0-30
											0-2.1
											630
											6-30
											0.4-2.1
											327
											3-27
											0.2-1.9
											060
											0-60
											0-4.1
											100
											0-100
											0-6.9
											120
											0-120
											0-8.3
											Maximum supply for these pressure ranges is 100 psig.
											Maximum supply for these pressure ranges is 140 psig.
											Specials
											00 None

It is mandatory for the user to install a suitably rated NRTL Listed or Certified conduit seal.

Terminal Block	I/P Transducer	E/P Transducer
S	N/C	+ Signal
+	+ Signal	+ Power Supply
-	- Signal	Common

Type 2000 Wiring Connections and Switch Positions

Switch #	1: psig	BAR	2	3	4	5	6: psig	BAR	7	8	9
ON	0-15	0-1.0	1-5 VDC 0-5 VDC	Split Low	Voltage Input (E/P)	Split Low or Full	0-15	0-1.0	Reverse Acting	Full	I/P
	3-15	0.2-1.0					1-17	0.07-1.2			
	1-17	0.07-1.2					0-30	0-2.1			
	0-30	0-2.1					3-27	0.2-1.9			
	3-27	0.2-1.9					6-30	0.4-2.1			
	6-30	0.4-2.1					0-100	0-6.9			
	0-100	0-6.9	0-120	0-8.3							
Switch #	1: psig	BAR	2	3	4	5	6: psig	BAR	7	8	9
OFF	0-60	0-4.1	1-9 VDC 0-10 VDC 4-20 mA	Full or Split High	Current Input (I/P)	Split High	3-15	0.2-1.0	Direct Acting	Split Low or Split High	E/P
	0-120	0-8.3					3-27	0.2-1.9			
							6-30	0.4-2.1			

Mounting Options

Mounting Method	Explosion-Proof (E) Model
In-Line	Yes
Direct Mounting	Side or Bottom Holes
Panel Bracket	Accessory
Valve Bracket – 316SS	Supplied
Pipe Bracket – 316SS	Accessory
DIN-Rail Bracket	Accessory
Manifold Plate	Accessory

Mounting: The Type 2000 can be mounted in-line, or directly to a panel via mounting holes located in the side and bottom of the unit. In addition, the E model includes a valve-mounting bracket. Kits are available for mounting to panel, valve, pipe, or DIN-Rail. A custom plate is available for mounting of the bottom-ported version to a manifold.
(See Accessories)

Sealing Fittings for FM approved T2000 EX Transducers

Application & Installation
Class I, Divisions 1 & 2

Seals in a Class I hazardous location is to minimize the passage of gases and vapors and prevent the passage of flames from one electrical installation to another through the conduit system. Seals are required to be installed within 18 inches on any conduit run entering an enclosure which contains devices that may produce arcs, sparks or high temperatures.

It is mandatory for a suitably rated conduit seal to be installed with the FM approved T2000 EXP Transducer.

Vertical or Horizontal Seals

All seal housings are approx. 3-1/2" in laying length and 1-1/2" OD

Part Number	Description
SF-04AMM	1/2" Aluminum
SF-04AMF	1/2" Aluminum w/nipple
SF-04IMM	1/2" Iron
SF-04IMF	1/2" Iron w/nipple

Sealing Materials

Per seal housing installed, approx. 1/16 oz of packing fiber is used for the dam and 1.5 oz of compound is used for the seal.

Part Number	Description
SC-4	4 oz. Sealing Compound
SC-8	8 oz. Sealing Compound
FP-4	4 oz. Packing Fiber

Larger quantities of fiber and compound available upon request.

Accessories

	Part Number
Panel Mounting Kit	010-135-000
Valve Mounting Kit – 316SS	010-134-000
2" Pipe Mounting Kit (Valve Mounting Kit is required)– 316SS	010-143-000
DIN Rail Adapter	010-115-000
Manifold Adapter Kit	971-158-000
Filter Kit, 60 microns	010-139-000
Pressure Gauge Kit 15 psig (1 BAR)	010-138-000
Pressure Gauge Kit 30 psig (2.1 BAR)	010-138-001
Pressure Gauge Kit 60 psig (4.1 BAR)	010-138-002
Pressure Gauge Kit 160 psig (11 BAR)	010-138-003

T2000 Specifications

Accuracy	0.1% of full-scale output typical (0.25% guaranteed); includes effects of hysteresis, dead band, and repeatability						
Electrical							
Inputs	Switch-Selectable 4-20mA. 0-5, 1-5, 1-9, 1-10, or 0-10VDC						
Connections	1/2 NPT or 20mm Conduit						
Power Supply	5-28VDC (with voltage inputs only)						
Direct/Reverse Acting	Switch-Selectable						
Pneumatic							
Outputs	PSIG	0-5, 0-15, 3-15, 1-17, 0-30, 6-30, 3-27, 0-60, 0-100, or 120					
	BAR	0-0.1, 0-0.3, 0-1.0, 0.2-1.0, 0.07-1.2, 0-2.1, 0.4-2.1, 0.2-1.9, 0-4.1, 0-6.9, 0-8.3					
Ports (Input/Output)	1/4 (NPT, BSPT, or BSPP threads) Bottom-ported for Manifold Mounting						
Exhaust	1/8 - 27 NPT						
Ports (Gauge)	1/8 NPT						
Supply	For 0-5 PSIG (0.3 BAR) Through 0-60 PSIG From 5 PSIG (0.3 BAR) above maximum output to 100 PSIG maximum For 0-100 PSIG and 0-120 PSIG Ranges From 5 PSIG (0.3 BAR) above maximum output to 140 PSIG maximum						
Split-Ranging	Switch-Selectable, Full-Range or Split-Range High or Split-Range Low						
Consumption	4 scfh maximum (1.9 LPM)						
Flow Capacity	Range		Sensor		Flow		
	PSIG	BAR	PSIG	BAR	scfm	LPM	
	0-5	0-0.3	5	0.3	11	312	
	0-15	0-1.0	15	1.0	15	423	
	3-15	0.2-1.0	15	1.0	15	423	
	1-17	0.07-1.2	15	1.0	15	423	
	0-30	0-2.1	30	2.1	15	423	
	3-27	0.2-1.9	30	2.1	15	423	
	6-30	0.4-2.1	30	2.1	15	423	
	0-60	0-4.1	50	3.5	15	423	
	(Typical Flow @ 100 PSIG (6.9 BAR) in and maximum out)						
	0-100	0-6.9	100	6.9	21	595	
0-120	0-8.3	100	6.9	21	595		
(Typical Flow @ 140 PSIG (9.7 BAR) in and maximum out)							
Exhaust Capacity	3 SCFM (85 LPM) @ 5 PSIG (0.3 BAR) above setpoint (0-15 PSIG range unit set at mid range)						
Stability							
Supply Voltage Effect	None						
Supply Pressure Effect	None						
Vibration Effect	<1% FS (+/-1G; 5-1000Hz)						
Mounting Position Effect	None						
RFI/EMI	CE-Compliant						
Temperature Effect	0.02% FS/°F (-40° to 180°F [-40° to 82°C])						
Storage Temperature	-40° to 200°F (-40 to 93°C)						
Approximate Weight	3.0 lbs, 1.35 kg						

Type 2000 Explosion Proof Dimensions

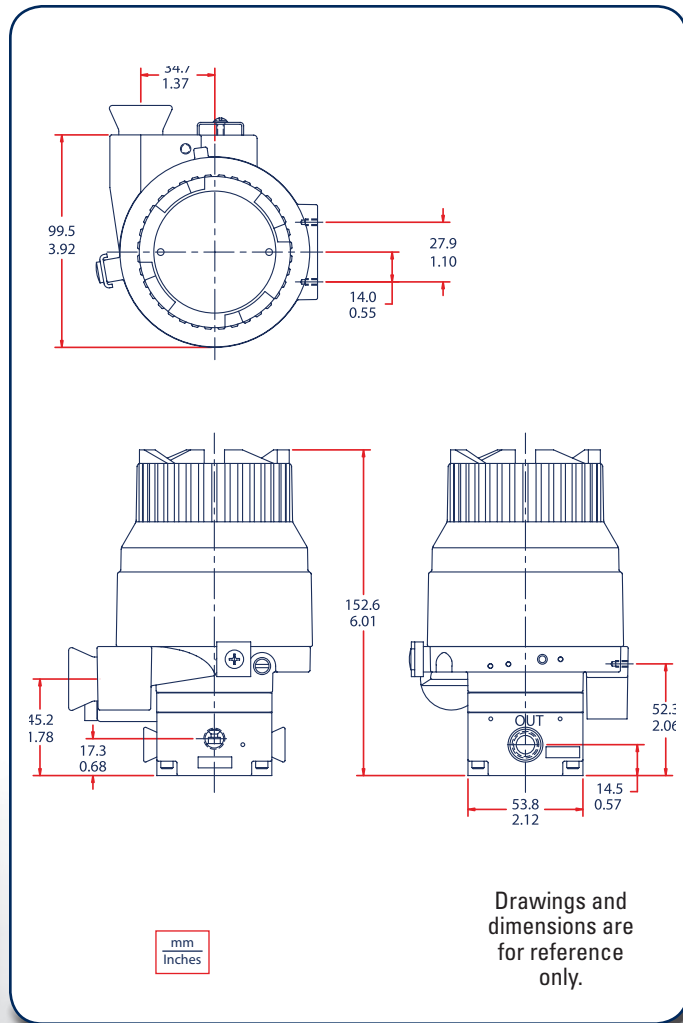

T2000 Agency Approvals

Factory Mutual

2K-ENaFbcde-00, T2000 I/P & E/P Transducers
 XP/I/1/ABCD/T6 Ta=60°C; DIP/II,III/1/EF/G/T6 Ta=60°C; Type 4X, IP66
 IS/I,II,III/1/ABCDEFG/T4 Ta=60°C – 990-438-000; Entity; Type 4X, IP66
 Non-Incendive/I/2/ABCD/T4 Ta=60°C; S/II/2/FG/T4 Ta=60°C; S/III/2/T4 Ta=60°C; Type 4X, IP66

Entity Parameters:

Input option b=42;
 Vmax = 30 V, Imax = 200 mA, Pmax= 1 W, Ci=0, Li=0
 Input option b=01, 05, 11, 15, or 19
 Vmax = 30 V, Imax = 100 mA, Pmax= 0.75 W, Ci=0, Li=0

a= Pneumatic ports

b= Input 01, 05, 11, 15, 19, or 42

c= Action D or R

d= Pneumatic Range F, H, or L

e= Pneumatic output 005, 015, 030, 060, 100, 117, 120, 315, 327, 630

Special Conditions of use:

The T-2000 is not for use with natural gas or other non-inert gases as a process medium.

2K-ENaGbcde-00, T2000 I/P & E/P Transducers

XP/I/1/ABCD/T6 Ta = 60°C
 DIP/II,III/1/EF/G/T6 Ta = 60°C; Type 4X, IP66

a= Pneumatic ports

b= Input 01, 05, 11, 15, 19, or 42

c= Action D or R

d= Pneumatic Range F, H, or L

e= Pneumatic output 005, 015, 030, 060, 100, 117, 120, 315, 327, 630

Special Conditions of use:

The T-2000 is for use with natural gas or other non-inert gases as a process medium up to a maximum input pressure of 140psi when installed with suitable NRTL Listed, Certified, or Approved conduit seal installed at the enclosure.

Canadian Standards Association

Explosion Proof: Class I, Division 1, Groups A, B, C, & D; Class II, Groups E, F, & G; Class III.

Rated: 28 Vdc, 8mA; T-code T6; Enclosure Type 4X, IP66; Max Ambient Temperature: +60°C

Intrinsically Safe, Entity – For Hazardous Locations: Class I, Divisions 1 & 2 Groups A to D; Class II Division 1 Groups E, F, & G; Division 2 Groups F & G; Class III Hazardous Locations

Rated: 28 Vdc, 8mA; T-code T6; Enclosure Type 4X, IP66;
 Max Ambient Temperature: +60°C.

Intrinsically Safe when installed per drawing 990-438-000.

Two sets of entity parameters may be used in the installation of this product.

Entity Parameters

I/P: Vmax = 30 V, Imax = 200 mA, Pmax = 1.0 W, Ci = 0mF, Li = 0mH

E/P: Vmax = 30 V, Imax = 100 mA, Pmax = 0.75 W, Ci = 0 mF, Li = 0 mH

CE Marking

The Type 2000 I/P or E/P transducers were tested and found to comply with the EMC directive 2004/108/EC. Compliance is based on the non-harmonized standards EN50081-1:1991 and EN50082-2:1994 along with a technical review against the harmonized standards EN61000-1:2007 and EN61000-2:2005 which showed that there were no changes which materially affected the "state of technological progress" with respect to the product.



REGULATED PRESSURE VS. FLOW

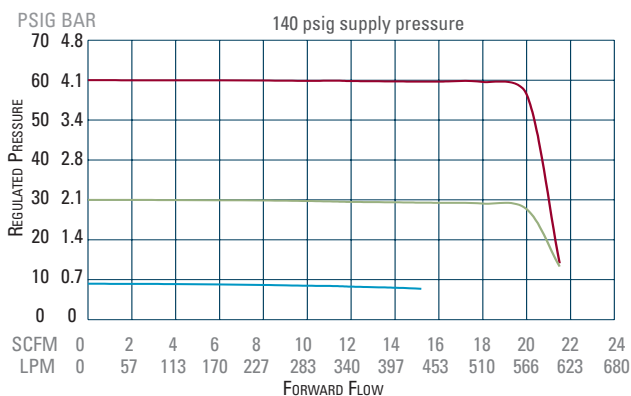

It is mandatory for the user to install a suitably rated NRTL Listed or Certified conduit seal